

Application of Series FACT Devices SSSC and TCSC with POD Controller in Electrical Power System Network

Abubakar Siddique¹, Yonghai XU¹, WaseemAslam¹, Fadi M. Albatsh²

¹School of Electrical & Electronics Engineering, North China Electric Power University, 102206, Beijing, China.

²Electrical Engineering Section, British Malaysian Institute, Universiti Kuala Lumpur, 53100, Selangor, Malaysia
Email: Engr.abs@yahoo.com

Abstract— with the growing power demand, it is vital to expand power transfer capacity of transmission lines. But the new expansion in our present transmission system is confined due to financial problems, environmental concerns and health hazards due to electric and magnetic fields. May be its worthwhile option to use flexible AC transmission system (FACTS) for enhancement of power capacity of transmission system. This paper presents, fruitfulness FACTS devices SSSC and TCSC with POD (Power oscillation damper) as additional controller. The major function is to decrease the peaks overshooting and clearing time of inter area oscillations, hence betterment in transient stability. For the fulfillment of analysis, time domain simulation outcomes are correlated for results verification. In addition, the parallel operation of SSSC for the system has been analyzed. This paper proposes modeling and simulation on MATLAB/Simulink Software for the proposed test system. Result displays that, power oscillation are rapidly damped than traditionally PSS by employing POD with FACTS-Controllers.

Index Terms—FACTS Controller, low frequency oscillation damping, MATLAB/Simulink, POD, Transient Stability.

I. INTRODUCTION

In present-day world, electrical power demand is increasing significantly over the last few decades. After all this growing rate of power demand does not pursue through the enrichment in power generating plants and transmission capacity. Thus in place of, to accommodate the increasing electric load requirement, power generation plants are operating at their maximum capacity[1]. Similarly transmission lines are also running nearer to their thermal limits. So, the power systems are seemly less sheltered and always carrying the exposure of voltage instability which has led to many major network collapses world-wide[2]. As the electric power system was not so complicated in previous times, the major controversy was to damping the local area oscillations which were simply performed by the aid of AVRs[3]. Then PSS appear which associated to the generators which present sizable concurrence towards the oscillations of the network. Hence traditionally PSS was employed for damping the local zones of oscillations in electric network[4],[5]. Different preventive measures as generation and transmission of energy adjourn, carrying reserve generators online, load curtailing and VAR back up by serial

or parallel capacitors are followed to conquered voltage instability controversy. However, most of them are electromechanical controller which got the demerits like sluggishness, wear and tear[6]. As an alternate key, intense consideration have been compensated to FACTS (Flexible Alternating Current Transmission System) devices which are directed from present-day components of power electronics, which could give active and reactive power accurately and keep the network stability limit[7]. In present paper FACTS devices with additional controller is employed for damping the power network oscillations. Thus by employing POD-FACTS the network power oscillations can be quickly damped as related with another commonly devices[8]. Since these controllers impact the driving voltage and thus the current and flow of power directly. For a given MVA size series controllers are manifolds robust than shunt controllers, in order to perform the desire functions such as to control the current/power flow and damping the oscillations[9].

The Static Synchronous Series Compensator (SSSC), one of the crucial FACTS device, subsists of a voltage-sourced converter (VSC) and a transformer linked in serial with a power line. The SSSC implants a voltage with changing magnitude in quadrature with the line current, hence mirroring an inductive or capacitive reactance. This mirrored changeable reactance in serial with the line hence has leverage on transmitted electric power. Therefore SSSC control wide range of power through transmission line. The fundamental construction of an SSSC is shown in Fig.1.

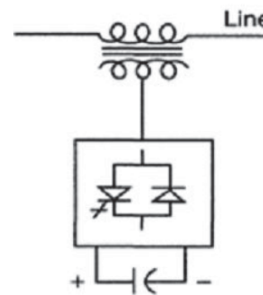

Fig. 1. Basic schematic of an SSSC.

The TCSC (Thyristor Controlled Series Compensator) is another series FACTS controller employed to provide series compensation for transmission line impedance in a regular,

rapid, and governable manner. The TCSC is linked in series with transmission lines[10]. The TCSC has immune impact to rising PTC (Power transfer capacity) and ATC (Available transfer capability) over transmission lines. Features alike automatic control of the thyristor has been combined into the TCSC. Consequently, the TCSC can be employed for increasing transient stability, alleviate SSR, and damp power oscillations. Fig. 2 shows a basic diagram of a TCSC in which a TCR is parallel linked with series fixed capacitor.

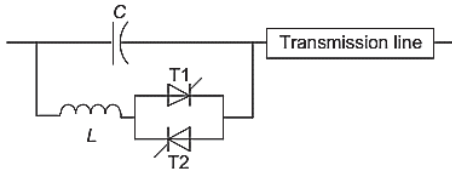

Fig. 2. Block diagram of TCSC.

In order to give compensation by assuring a rise in the stability which in turn increases the flow of power and damped the power oscillations, the compensation techniques the devices alike SSSC and TCSC with supplementary POD are employed. The switching converter employs self-commutating switches like GTO, IGBT. The switching converter sort has manifold merits like rapid response, desires lesser space, re-locatable and modular.

II. CONTROL BLOCK DIAGRAMS OF SSSC, TCSC AND POD.

A. SSSC

The SSSC implants a voltage in serial with the line regardless of the line current. The SSSC can yield inductive and capacitive compensating voltage regardless of the power line current equal to the rated current of the line. In voltage compensation zone, the SSSC can keep the rated capacitive and inductive compensating voltage irrespective of the varying line current.

The control scheme block diagram is denoted in Fig.3.

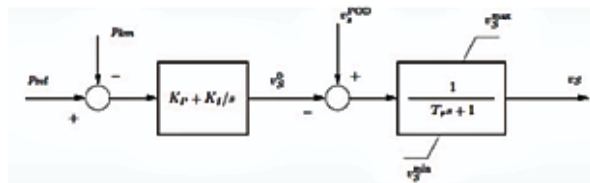

Fig. 3. Control Block Design of SSSC

B. TCSC

TCSC can be governed to perform in both capacitive and inductive fashions averting steady state resonance, as shown in Fig.4. The TCSC impedance characteristics represents inductive and capacitive zones are feasible by changing the firing angle α . In inductive mode the inductance increases from a minimum value to a maximum value of infinity at resonance. Similarly, in the capacitive mode,

capacitance decreases from infinity to a minimum value..

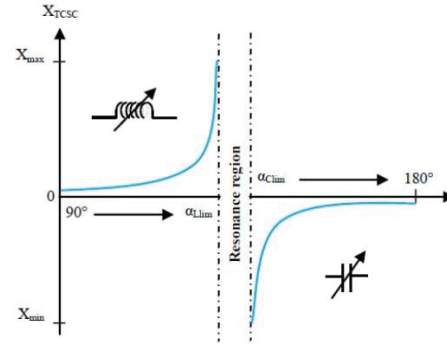

Fig. 4. Impedance Diagram of TCSC.

The control scheme TCSC regulator is denoted in Fig.5

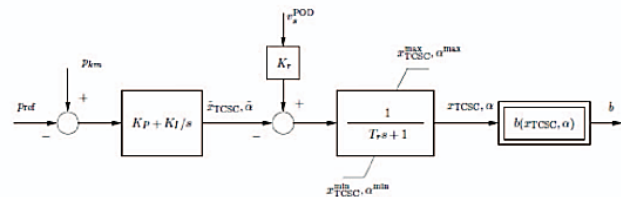

Fig. 5. Control Block Design of TCSC

C. POD

POD gives supplementary input signal to AVT for damping the network oscillations. Generally bus voltage, line current, real and reactive power from the bus are the enforced input signals [12]. For maintaining the damping, there is necessary for POD to give electrical torque component which is in phase to speed of rotor diversion ($d\omega_r$).

POD subsist of distinct blocks, gain block finds the magnitude of power oscillations confer to its gain value. Washout block shows high pass filter and assure at normal state outcome of POD is zero. Phase compensating block gives the adequate phase lead properties for compensating the phase lag betwixt the input of exciter and torque of alternator. Time constant block manage the proper time lag for controllers. POD block diagram is shown in Fig.6.

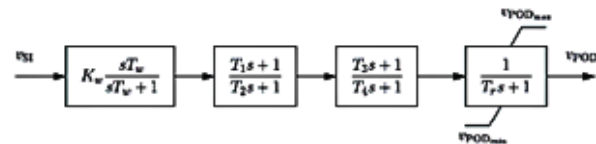

Fig. 6. Block design of POD

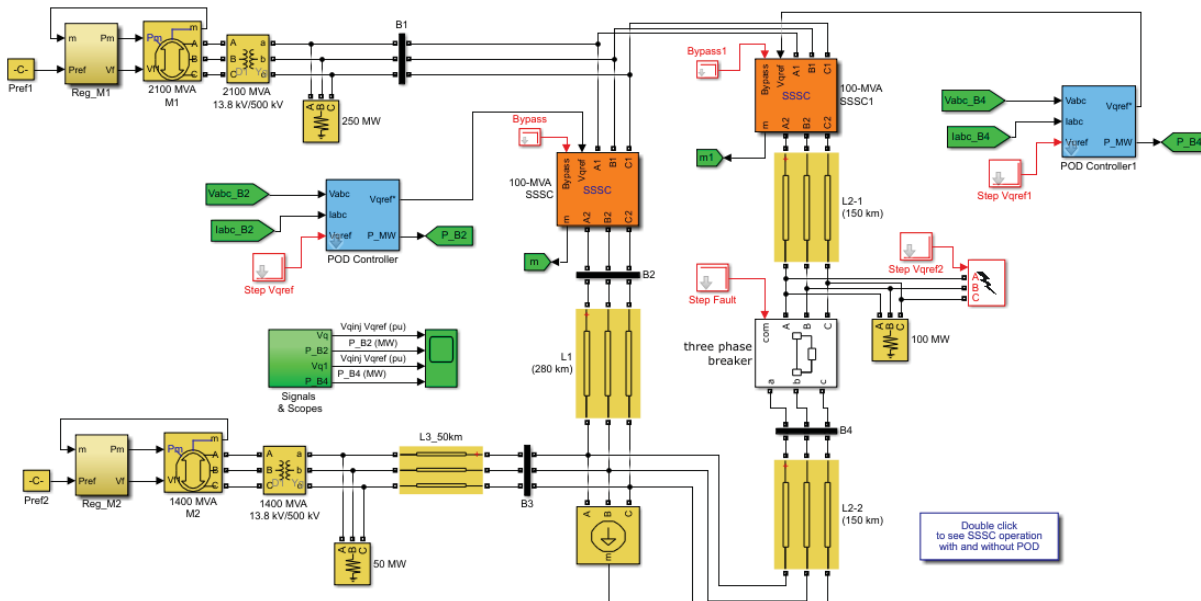

Fig.9 System with parallel operation of SSSC

The power network (Fig.7, 8, 9) subsists of two substations (M1 and M2) and one main load center at bus (B3). First power generating substation M1 is rated as 2100 MVA and it showing six machines with rating of 350 MVA each. The second one substation M2 is rated as 1400 MVA exhibiting four machines with rating of 350 MVA each. The load center near about 2200 MW is formed by employing a dynamic load model, where consumed real and reactive power by a load is a function of voltage of the network. The substation M1 is associated to this load with two transmission lines (L1 and L2). The length of line L1 is 280 km, where line L2 has length 350 km and it is divided into two segments of 150 km each so that to simulate a three phase fault (by employing a fault breaker) at the middle point of the line. The substation M2 is linked with the load through a 50 km line L3. With omitting SSSC, the flow of power approaching to this main load is pursue as: 664 MW flow of power measured at bus B2 on line L1, 563 MW flow of power measured at bus B4 on line L2, and 990 MW flow of power measured at bus B3 on line L3. The SSSC is rated as 100 MVA is placed at bus B1 in series with line L1 and it is able to implant up to 10% of the nominal network voltage. The reference implanting voltage is intent by power oscillation damping (POD) controller whose outcome is linked with reference input voltage of SSSC. The voltage at bus B2 and current through a line L1 are the inputs of POD controller.

IV. RESULT AND DISCUSSION

In this section the results got from simulation for proposed system are presented.

Fig.10 shows results with power oscillation damper is off. It can be seen that there are oscillations in bus power. The X-axis of chart shows the simulation time and Y-axis depicted with V_{qj} , V_{qref} (pu) and power at bus B2 [P_{B2} (MW)].

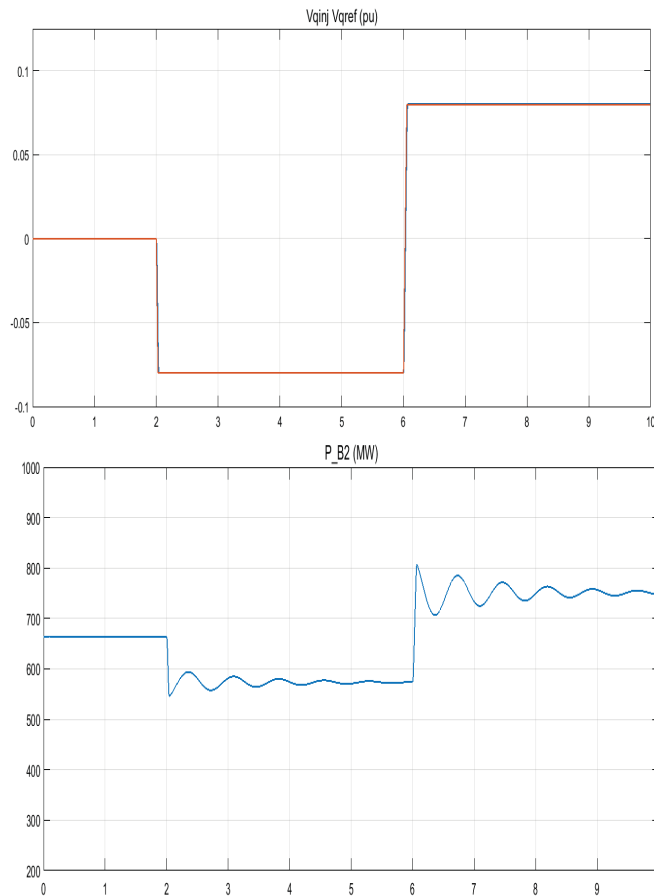

Fig. 10. SSSC inductive and capacitive mode without POD

RESULTS FOR SSSC WITH POD

From Fig.11, it can be seen that when POD turned on the power oscillations are drastically reduces

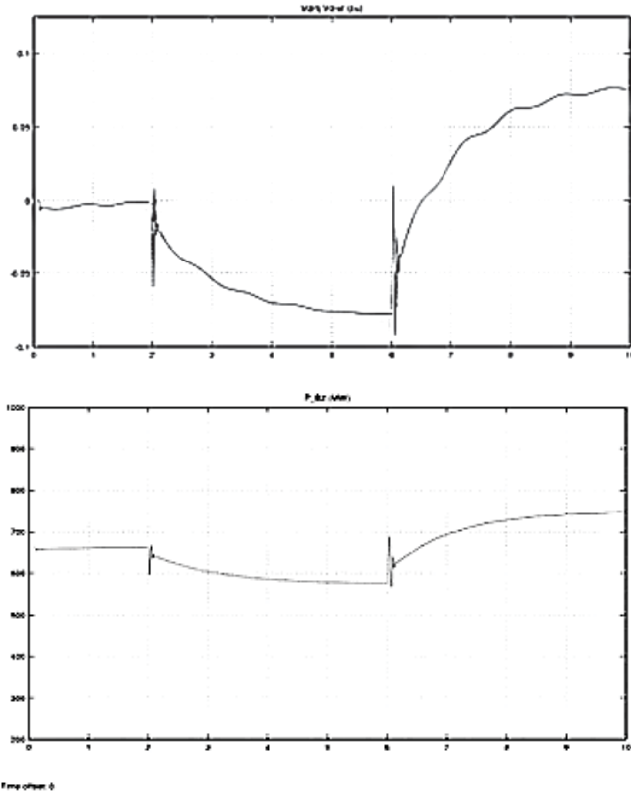

Fig. 11. SSSC Capacitive & inductive operation with POD on

From the Fig.12 [(a), (b) and (c), (d)], it is shows that the simulations for both POD status ON and OFF. At 2 sec SSSC is switched to inductive mode and at 6 sec to capacitive mode. It can be easily seen that there is a significant difference between oscillation damping for both cases. SSSC operation is therefore more efficient with POD controller.

The X-axis of chart depicts the simulation time and Y-axis shows the real and reactive power respectively

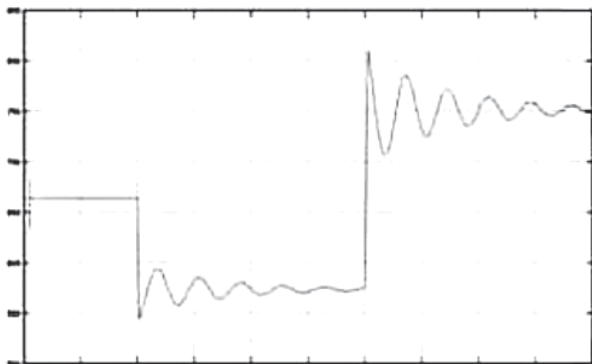

Fig. 12 (a) POD OFF

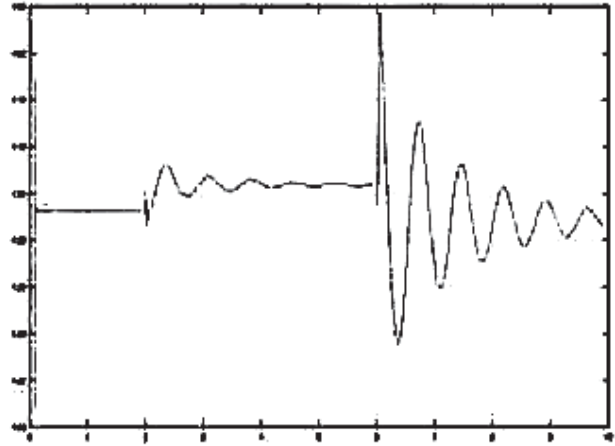

Fig. 12. (b) POD OFF

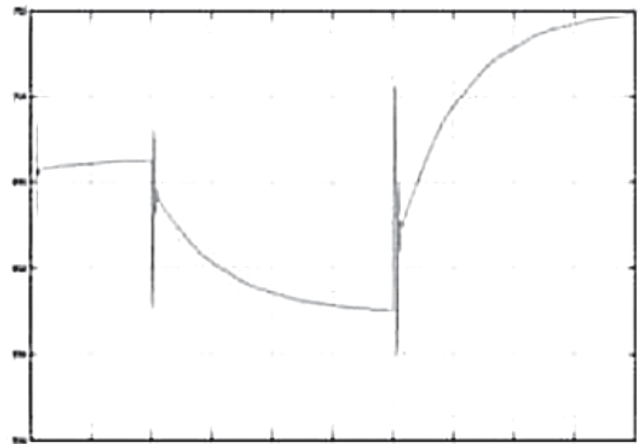

Fig. 12. (c) POD ON

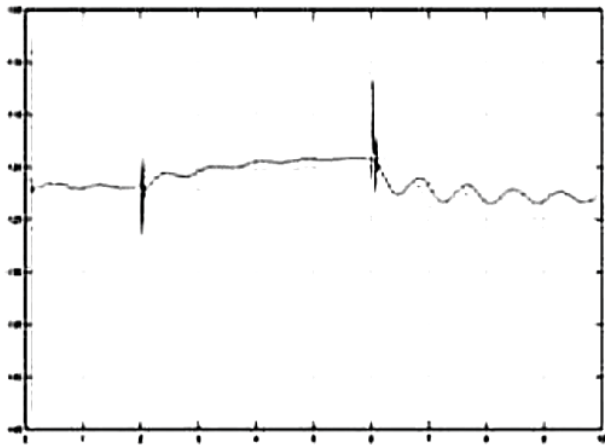

Fig. 12 (d) POD ON

Fig.12 [(a), (b), (c), and (d)]

Flow of real and reactive power through the bus2
OPERATION WITH FAULT

From Fig.13 it is seen that, a three-phase fault is enforced at 1.33 sec. The fault duration is 10 cycle (0.166 sec). It can be seen from the figure-13 that with POD ON, the oscillations are damped in less than a second whereas for operation without POD the power oscillations continue and the settling time is greater than 5 seconds. It also shows that SSSC is very useful to improve transient stability. (On graph X-axis labeled with time and Y-axis labeled with power in MW on line1).

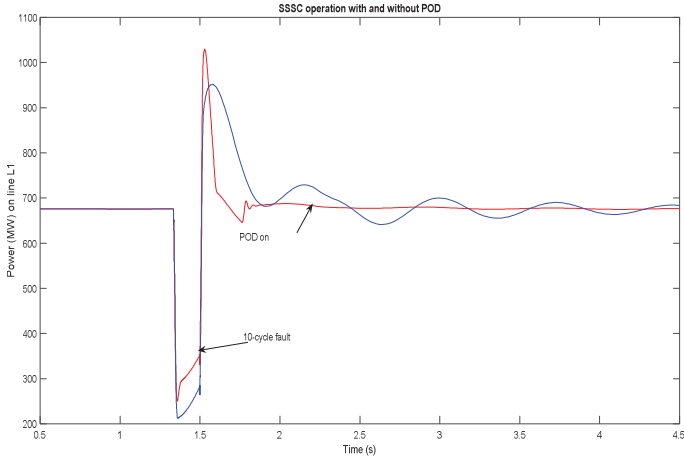

Fig. 13. Fault analysis with and without SSSC-POD

RESULT OF SSSC WITH POD FOR PARALLEL OPERATION

The X-axis of graph denotes the simulation time and Y-axis displays V_q inj, V_q ref (pu) and power at bus B2 and bus B4 respectively. As $[V_q$ inj, V_q ref (pu) and P_{B_2} (MW)], similarly for bus B4 $[V_q$ inj, V_q ref (pu) and P_{B_4} (MW)]

RESULT WITH TCSC

From the Fig.14, it can be seen that when at 5 second the bypass of TCSC is opened and TCSC (capacitive mode operation) comes into operation, after which the power through line is increased to 720 MW (which was initially 600 MW).

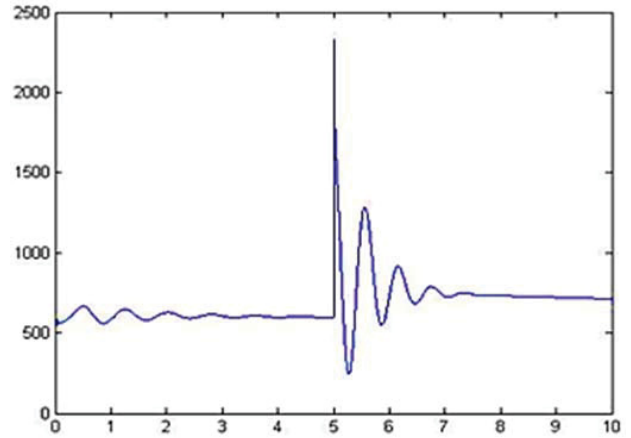
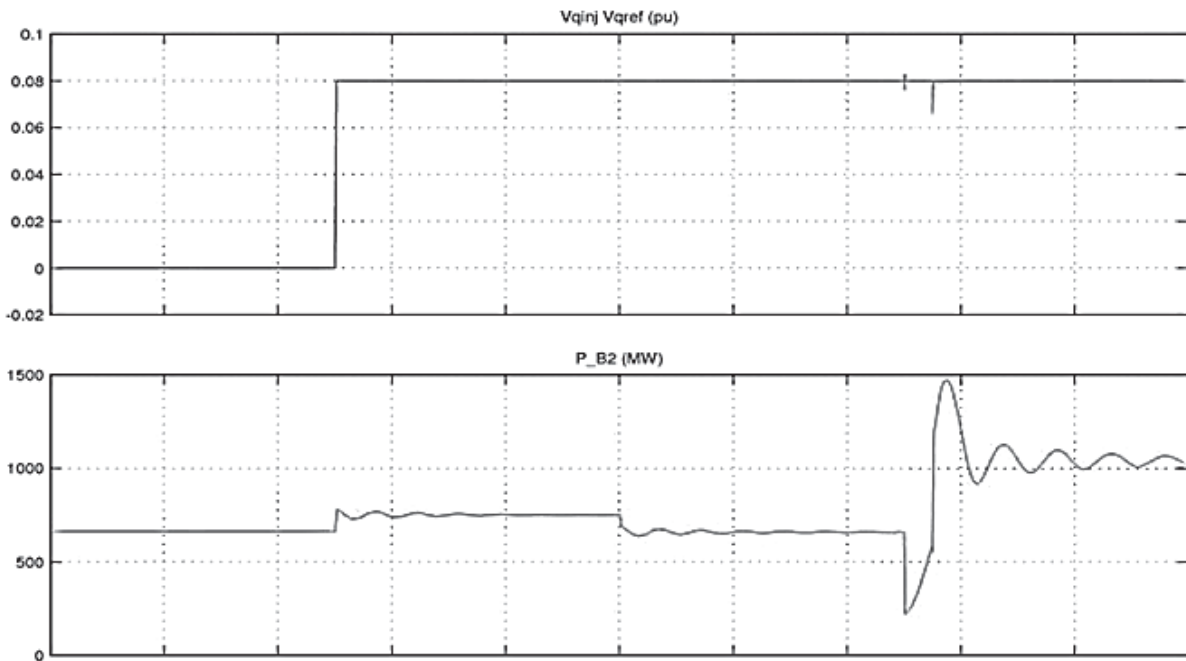

Fig. 14. Power flow in capacitive mode



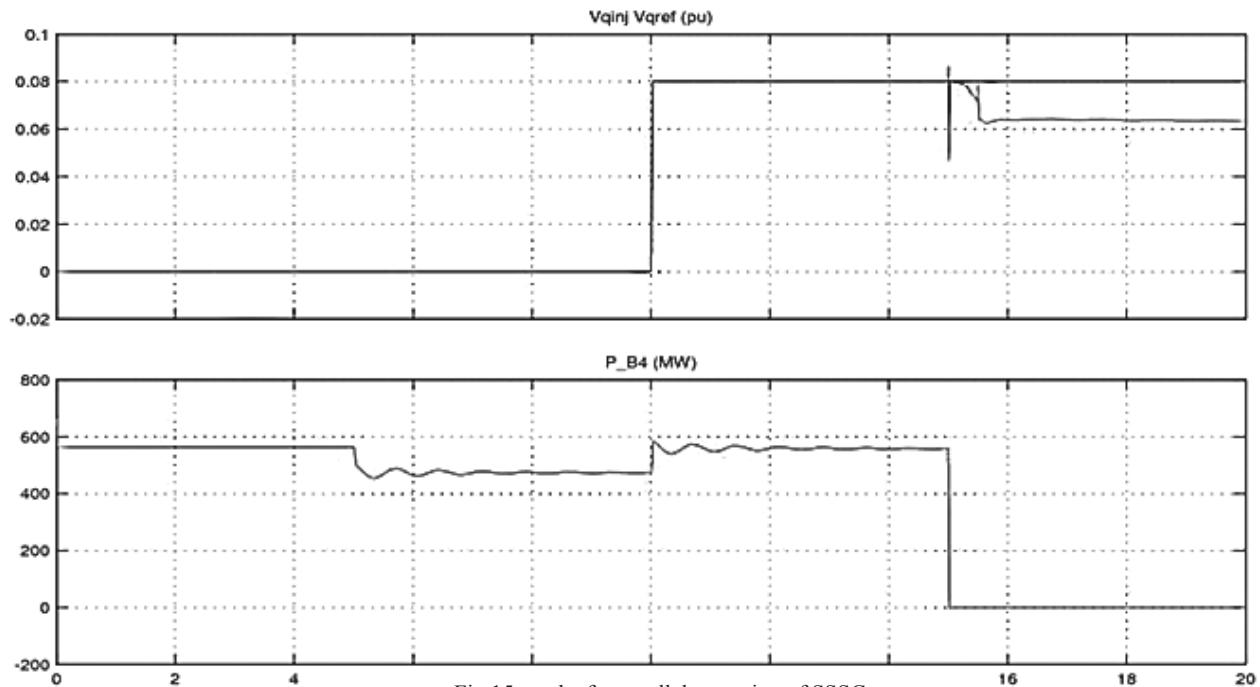

Fig.15 results for parallel operation of SSSC

Fig.15 displays the voltage and real power at buses (B4, B2) with parallel operation of SSSC. It can be seen that at 5 Sec, SSSC at bus-2 is turned on this results into power transfer increase through this bus-1 and decrease in power transfer through the bus-4. At 10 sec SSSC at bus 4 is turned on, this results into power transfer increase through this bus-4 and decrease in power transfer through the bus-1. At 15 sec, fault at the transmission line (bus-4) occurs. At 15.5 sec, fault removed by opening the circuit breaker. Now after this all power will transfer through bus-1.

V. CONCLUSION

This paper presents the electric power network with different loads linked at distinct buses as a test network with FACTS-POD controller by accomplishing a time domain simulation in MATLAB/Simulink software. The enforced POD gives stabilizing signals to the FACTS devices. For the investigation of series FACTS-POD, a 3-phase fault is activated at time 1.33 sec having fault duration is 0.166 sec. Results revealed that SSSC with POD has superior potential for damping the network oscillations as compared to TCSC controller. In addition SSSC-POD rises real and reactive power of the system, hence improving load capacity of the network. Thus it can be concluded that power oscillation damping and PTC of the power network with various loads at distinct buses increased by employing SSSC and TCSC with additional POD controller.

VI- REFERENCES

[1] ALBATSH F M 2015 Enhancing power transfer capability through flexible AC transmission system devices: a review *Front. Inf. Technol. Electron. Eng.* 16 658–78
 [2] T. S. Ustun and S. Mekhilef, "Effects of a Static

Synchronous Series Compensator (SSSC) Based on a Soft Switching 48-Pulse PWM Inverter on the Power Demand from the Grid," *Journal of Power Electronics*, vol. 10, pp. 85-90, Jan. 2010.

- [3] P. Kundur, J. Paserba, V. Ajjarapu, G. Andersson, A. Bose, C. Canizares, N. Hatzargyriou, D. Hill, A. Stankovic, C. Taylor et al., "Definition and classification of power system stability ieeecigre joint task force on stability terms and definitions," P
 [4] M. Eslami, H. Shareef, and A. Mohamed, "Optimal tuning of power system stabilizers using modified particle swarm optimization," 2010.
 [5] E. Gholipour and S. Saadate, "Improving of transient stability of power systems using upfc," *Power Delivery, IEEE Transactions on*, vol. 20, no. 2, pp. 1677–1682, 2005.
 [6] M. E. Elgamal, A. Lotfy, and G. Ali, "Voltage profile enhancement by fuzzy controlled MLI UPFC," *International Journal of Electrical Power & Energy Systems*, vol. 34, pp. 10-18, 2012.
 [7] J. Tibin, X. Sini, S. Chitra, V. Cherian et al., "Pso based optimal placement and setting of facts devices for improving the performance of power distribution system," *Bonfring International Journal of Power Systems and Integrated Circuits*, vol. 1, no. In
 [8] E. Ghahremani and I. Kamwa, "Joint improvement of system loadability and stability through a multi-stage planning of a upfc with a pmu-based supplementary damping control," in *Power and Energy Society General Meeting (PES), 2013 IEEE. IEEE, 2013*, pp. 1–5.
 [9] N. G. Hingorani, L. Gyugyi, and M. El-Hawary, *Understanding FACTS: concepts and technology of flexible AC transmission systems*. IEEE press New York, 2000, vol. 1.
 [10] A. Nabavi-Niaki and M. R. Iravani, "Steady State and Dynamic Models of Unified Power Flow Controller (UPFC)," *IEEE 96 Winter Meeting, 1996*. Paper 96.